



## **Frameless Glass Barn Door 93 Series**

The Frameless Glass Barn Door is more than a decorative sliding door solution. Elegant in design, this system is completely trackless. Its commercial grade brushed stainless steel system with ball bearing rollers offers a smooth and quiet operation. The 3/8" tempered glass has acid etching on both sides that offers a consistent glass surface look. The opaque glass finish provides utmost privacy while allowing natural light to pass through.

This sleek door system is perfect not only for multi-family residences, but hotels and high-end office spaces, looking to maximize space while adding an urban interior touch.

Hardware: Face mounted stainless steel barn door  
Glass Options: Acid Etched (2-sides)

# Frameless Glass Barn Door 93 Series

## Specifications

### Materials

304 Stainless steel track and hanger  
Nylon coated stainless steel wheel

### Finish Option | Glass Option

Brushed Stainless Steel | Acid Etched 2 Sides

### Door Specifications

Glass door weight - up to 250 lbs  
Glass door thickness - 3/8"

### Standards

ANSI/BHMA 156.14 (Grade 1) compliant

### System includes:

Stainless steel track (60" - 64" - 72" - 84")  
2 Hangers  
Wall brackets  
1 Bottom guide  
1 Finger pull  
2 Track stops  
Mounting and installation hardware

HANGER | TRACK | STOP

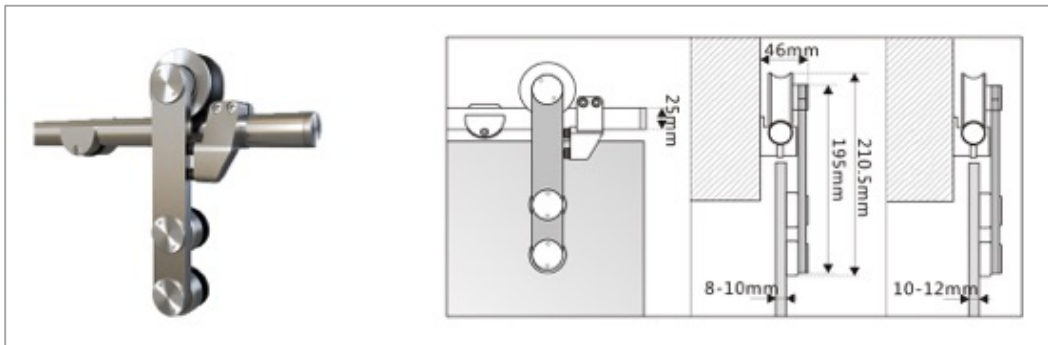

FINGER PULL

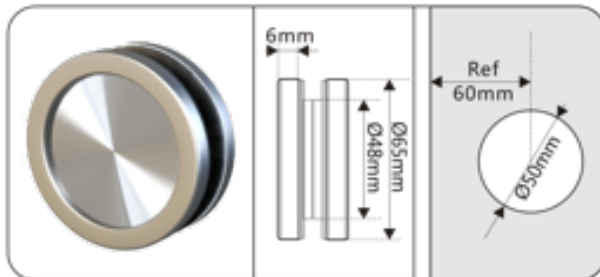

BOTTOM GUIDE

